

# STARCOOL III OWNERS MANUAL



Sportsmobile



## STARCOOL RV AIR CONDITIONER    MODEL SERIES III

### EXCLUSIVE STARCOOL FEATURES:

- **COOLS DRIVING (12V) & PARKED (110V)** – from a single system using ozone friendly R-134A refrigerant.
- **SWITCHES AUTOMATICALLY** – from 12V to 110V operation.
- **CENTRAL LOCATION, WITH DUCTS TO FRONT & REAR** – Provides uniform cooling even when a bifold door or partition curtain is used. Individual air duct vents (4) can be adjusted to concentrate cool air to front or rear.
- **FLEXIBLE INTERIOR LOCATION** – The Starcool evaporator/blower assembly can be mounted almost anywhere in the Sportsmobile. The cold air discharge ducts can also be located for the best cooling locations.
- **ONLY 1 CF OF INTERIOR SPACE** – is required for the Starcool evaporator/blower. Some additional space is also required for the air ducts.
- **REDUCED A/C NOISE IN CAB WHILE DRIVING** – You can turn your dash A/C to low and your Starcool A/C to low for quiet operation and efficient cooling.
- **SPECIALLY ENGINEERED FOR VAN MOTORHOMES** – Starcool A/C lines attach at factory dash air conditioner connection points for greater reliability. The 110V compressor has been engineered to ensure proper oil circulation (PATENTED). Pressure switches, relays and fuses protect the van's A/C and the Starcool. All Starcool parts are heavy duty and rated for continuous operation.
- **INTEGRATED TO VAN'S A/C** – Starcool is installed like the factory dash A/C and other rear A/C systems.
- **LOWERS VAN ENGINE OPERATING TEMPERATURES** – This is accomplished by a condenser fan mounted behind the van's grill. The fan moves approximately 1000CFM of additional air flow over the condenser. This additional air flow lowers the van's engine operating temperature when driving or parked.
- **COLDER AIR FROM THE VAN'S DASH A/C** – while the van's engine is idling. This is the result of the above increased air flow over the van's condenser.
- **KEEPS WEIGHT LOW** – The heaviest component of an air conditioner is the compressor. Starcool's hermetically sealed compressor is located safely up under the van's floor.
- **COMPLETELY CONCEALED** – Nothing shows from the outside of the Sportsmobile, not even a rear vent in the rear of the top. U.S. Patents 4,947,657 and 5,435,144.

### ADDITIONAL FEATURES:

- **THREE BLOWER SPEEDS** – For maximum cooling or quiet cooling. Continuously re-circulates interior air.
- **REMOTE THERMOSTAT** – cycles the Starcool 110V compressor while allowing continuous air circulation.
- **PROVEN DESIGN** – In production since 1989. In use throughout the U.S.
- **STARCOOL USES R-134A** – Ozone friendly. Roof A/C's use R-22 (not ozone friendly).
- **SERVICE** – If there is ever problem, any independent automotive A/C service center or Sportsmobile plant can service it. Please call for an appointment in advance. A detailed easy to read service manual is available.
- **WARRANTY** – Industry standard limited warranty 12 months or 12,000 miles.

## STARCOOL OPERATION

### DRIVING 12V

1. The vehicle's cab area will be cooled by 12V in-dash air conditioner.
2. The Starcool, running on 12V, will help cool the rest of the vehicle's interior.

### PARKED 110V

1. The Starcool, running on 110V, will help cool your vehicles interior when you have an outside 110V hook-up, or a generator.
2. The 110V Power converter/Battery charger will keep your Extra Battery charged to operate the three speed Starcool 12V blower, auxiliary condenser and condenser fan that is located behind the van's grill.

### OPERATION DRIVING 12V

1. Please see your vehicle's operating manual for the vehicle's in-dash air conditioner.
2. Set the Starcool fan switch to the desired speed – low, medium, or high.
3. The Starcool thermostat does not work when you are driving. It only works when you are parked, and on 110V power. The heat selector on the Starcool thermostat will operate the optional furnace when parked or driving.
4. Cab noise can be reduced by switching the dash A/C fan to low and Starcool to low, medium, or high. The temperature of the air blowing out of the vents is actually colder when the fan is switched to a lower speed.

### OPERATION PARKED 110V

1. Turn vehicle ignition switch to "Off", not to accessory.
2. Connect the 110V power cord to an outside 110V hookup.
3. Set the Starcool fan switch to the desired speed – low, medium, or high.
4. If you have a generator, allow five minutes, after you stop the vehicle engine, before proceeding.
5. Set thermostat to "Cool", and select the desired temperature range.
6. Once the interior temperature reaches the desired thermostat setting, the Starcool's 110V compressor will cycle off. The blower fan will continue to circulate the interior air – until the Starcool fan switch is turned off.

### TO RETURN VEHICLE'S 12V A/C AND STARCOOL TO 12V OPERATION

1. Set thermostat to "Off".
2. Disconnect the 110V power cord.
3. Start the vehicle's engine.
4. Turn factory dash A/C "On".
5. Turn Starcool fan switch to low, medium, or high.

#### **REAR BLOWER SWITCH**

See Page 4

This additional switch makes it convenient for the driver to turn the Starcool blower on and off.

- **IMPORTANT – When "running" dash A/C – always turn this switch "ON".**
- **When "NOT" running dash A/C – turn this switch "OFF".**

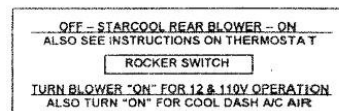

## ROUTINE MAINTENANCE

1. **OPERATE YOUR STACOOOL PERIODICALLY** – On 12V and 110V for a while at least once a month.
2. **A/C FILTER** – Remove air vent in front of Starcool's evaporator. Check filter once a month. Wash in water as needed

## MISCELLANEOUS

### 1. **DOES THE STARCOOL AFFECT THE VAN'S WARRANTY?**

Starcool connects into the same existing vehicle A/C high and low pressure refrigerant lines that an auxiliary rear 12V air conditioner evaporator does. The system does not affect the van's warranty. The Starcool actually puts less strain on the vehicle's compressor, by allowing the refrigerant to pass by the Starcool auxiliary condenser fan for extra cooling. This allows the vehicle's A/C compressor to work less, and at lower refrigerant pressures.

### 2. **SYSTEMS PROTECTION** - Pressure switches, relays, and fuses protect the vehicle's A/C and the Starcool.

### 3. **SUPPOSE I HAVE A PROBLEM - HOW DO I GET PARTS, SERVICE?**

First, the Starcool is a heavy duty unit. The parts are rated for "Continuous" operation. Any A/C service facility should be able to easily service the system. Any Sportsmobile plant can also service your Starcool. Please call in advance for an appointment.

### 4. **WHICH PART IS MOST LIKELY TO FAIL?**

It is unlikely any part will fail. Should this happen, it will probably be a relay, which is easy to replace. There are 4 relays, 4 fuses and 2 circuit breakers to protect and control the system. Their capacity exceeds their use.

### 5. **ROUTINE MAINTENANCE** - It is important to clean the reusable air filter on the Starcool Evaporator/Blower every month, as poor performance will result if the filter is neglected. For access, remove the lower intake grill (2 screws). **Important – replace grill.**

## WHAT CAN YOU EXPECT FROM THE STARCOOL AIR CONDITIONER?

1. The Starcool Air Conditioner operates the same way that a roof air conditioner operates when on 110V.
2. The following information is from Coleman's RV Owners Manual and applies to any RV A/C including Starcool. The size of RV air conditioners is generally limited to about 13,500 BTUH (approximately one ton) of cooling. This is due to the limited electrical power normally available in most trailer parks and/or economic limitations on the use of generators with enough capacity to handle large air conditioners.

The ability of the air conditioner to maintain the desired inside temperature depends on the heat gain of the RV. This depends on the size of the vehicle, amount of window area, amount of insulation, direct exposure to the sun, outside temperature, the number of people in the RV, etc. It's possible that under certain conditions the heat gain of an RV can exceed the capacity of the A/C.

As a general rule, air entering the air conditioner will be cooled about 15° to 20°, depending on the outside temperature and humidity conditions.

For example, if the air entering the return air grill in the air conditioner is 80° F, the air leaving the discharge vents will be 60° to 65° F. As long as this temperature difference is being maintained between the return air and discharge air, the A/C is operating at its capacity. If the desired inside temperature (normally 80° F) cannot be maintained, then the heat gain of the RV is too great for the capacity of the air conditioner. Larger RVs may require 2 or more roof air conditioners.

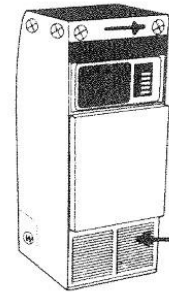

60° - 65°  
Check "Outlet" temperature  
inside vent.

80°  
Check "Inlet" temperature  
inside vent.

---

## WHAT YOU CAN DO TO HELP COOL YOUR SPORTSMOBILE?

Your Sportsmobile is very well insulated, but keep in mind it has a steel body and lots of windows. Steel and glass are excellent heat conductors. Hot travels to cool, so anything you can do to keep the heat from entering your Sportsmobile is a plus.

1. **Park under shade** - whenever possible. Of course parking on grass is much better than the extreme of parking on black asphalt in the heat of day.
2. **If you park in the sun** - have the sun to the rear of the Sportsmobile when you can.
3. **Windshield and cab door windows** - The windshield and cab door windows let in a lot of solar heat gain. Especially if you are facing into the sun. Sportsmobile windshield and cab door screens are made of white fiberglass and will block 70% of this heat gain. These screens also provide daytime privacy. You can see out. They can't see in.
4. **Other windows** - Window tinting is very effective. Exterior white fiberglass screens are also available.
5. **Curtains/Shades** - Closing these also will help keep the heat out.
6. **Let the hottest air out** - Crack the upper windows or open a roof vent some. If you have a Penthouse top unzip the corners of a couple of the plastic windows. It's easier to cool 100° air than 120°.
7. **For faster cool down** - When you are parked, idle the van's engine for 30 minutes or so. Turn both the van's dash A/C and the Starcool blowers to high. **Warning** - never idle your van's engine when parked over grass as the catalytic converter could start a fire.
8. **Open hood** - Engines build up a lot of heat when driving. To quickly dissipate this heat and help keep it from entering the Sportsmobile, we suggest you open the van's hood when you stop at the campground.

## STARCOOL, SGW (SOMETHING GONE WRONG)

### SGW – “DRIVING 12V”

#### 1. STARCOOL BLOWER FAN DOES NOT OPERATE

- A. The blower fan is connected to the evaporator and is located toward the rear of the vehicle.
- B. Check Starcool fuses located on relay plate near the 12V distribution center. See drawing. If new fuse blows, this indicates there is a short in the wiring or the blower motor is defective.
- C. If dash blower fan does not operate, check for blown fuse at factory fuse block. See vehicle's operation manual.
- \*D. Check power to blower motor.
- \*E. Check black ground wire to blower motor. If blower still does not operate – replace blower.

#### 2. BLOWER FAN OPERATES – AIR DOES NOT COOL

- A. Check that vehicle's dash temperature selector is set in cool range.
- B. Check air filter. See “Routine Maintenance” in Miscellaneous Section.
- C. Verify that the dash air control flap is operating properly. Warm air should be present when dash temperature selector is set to warm, and cool when set in cool range. If the air control flap is not working, an automotive repair company can repair it.
- D. Verify that the compressor clutch on vehicle compressor is engaging. When the dash control is set to normal or maximum position, you should hear a click noise and hear a change in the engine RPM.
- \*E. Confirm that thermostat is set to “off” position while Starcool blower switch is set to low, medium or high. (Thermostat is typically useless while the vehicle is on, but could energize the solenoid valve if ignition on relay is not energized.)
- \*F. Check for blockage in high pressure line to orifice tube or expansion valve. Frosting or sharp temperature difference on line will occur at point of blockage.

#### 3. VEHICLE COMPRESSOR CYCLES RAPIDLY WHILE DRIVING AND/OR LOSS OF COOLING

- A. Most likely indicates a loss of refrigerant. Note – if the vehicle's refrigerant level is okay, the Starcool's refrigerant level is also okay.
- B. Check for a leak, sometimes the factory charge ports will leak.
- C. After a leak is fixed, a recharge of refrigerant is typically all that is required.
- \*D. When having a leak repaired, it is important that a sufficient vacuum be pulled. A maximum level of 400 microns must be obtained. Lower levels are not desirable.
- \*E. The system should be recharged like any typical automotive A/C system. The refrigerant capacity is indicated on a label under the hood.
- \*F. Check vehicle fuse panel for blown fuse, replace as needed.

**\* IT IS RECOMMENDED THAT A QUALIFIED A/C PERSON CHECK THESE ITEMS.**

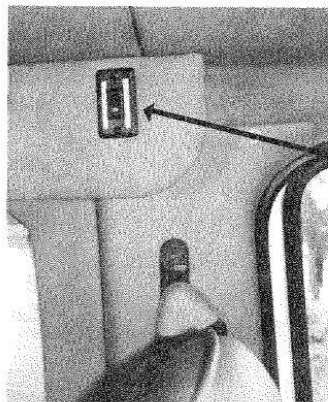

See Page 2

#### REAR BLOWER SWITCH

OFF – STARCOOL REAR BLOWER – ON  
ALSO SEE INSTRUCTIONS ON THERMOSTAT  
ROCKER SWITCH  
TURN BLOWER “ON” FOR 12 & 110V OPERATION  
ALSO TURN “ON” FOR COOL DASH A/C AIR

This additional switch added 06/00 makes it convenient for the driver to turn the Starcool blower on and off.

**IMPORTANT** – ALWAYS TURN THIS SWITCH “ON” WHEN RUNNING VANS DASH A/C.

TURN “OFF” WHEN NOT USING THE VANS DASH A/C.

**CONDENSOR FANS (2)** Periodically inspect these fans. Remove any debris.

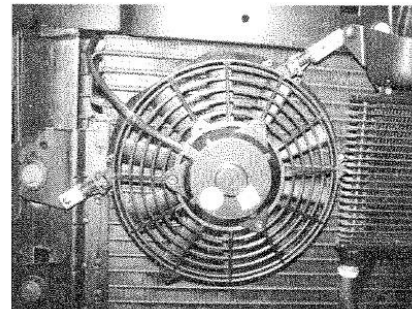

**FRONT CONDENSOR FAN** (above photo) is located behind the vans front grill. It can be inspected and cleaned through the grill.

**REAR CONDENSOR FAN** is located under the drivers side of the van just behind the front tire.



<b>SGW - "PARKED 110V"</b>
----------------------------

**1. STARCOOL BLOWER FAN DOES NOT OPERATE**

- A. The blower fan is connected to the evaporator and is one assembly. This component is located in a cabinet behind the return air vent.
- B. Check Starcool fuses located on relay plate near the 12V distribution center. See drawing. If new fuse blows, this indicates either there is a short in the wiring or the blower motor is defective.
- \*C. Check power to blower motor.
- \*D. Check black ground wire to blower motor. If blower still does not operate – replace blower motor.

**2. BLOWER FAN OPERATES - AIR IS NOT COOL**

- A. Verify that vehicle ignition is "off".
- B. Check that thermostat switch is set to "Cool" and temperature selector is set below vehicle interior temp.
- C. Check 110V power cord connections to ensure power is entering vehicle.
- D. Check 110V circuit breakers. Verify 110V compressor is operating. The compressor is located under the vehicle. When it cycles on, you can hear it running.
- E. Check return air filter. See "Routine Maintenance" in Miscellaneous Section.
- \*F. Check for blockage in the high pressure line to orifice tube. Frosting or sharp temperature difference will occur at point of blockage.
- \*G. Verify that solenoid valve is operating. A "click" can be heard initially when the Starcool fan switch is turned to "low", "medium" or "high".

**3. STARCOOL CONDENSER FANS DO NOT OPERATE**

- A. Fans are located in front of the factory condenser behind the van's grill and under the vehicle.
- B. If no power is present, check fuse located on relay plate by 12V distribution center.
- \*C. Check power to fan. If power is present, check ground wire or replace fan motor.

**4. STARCOOL COMPRESSOR CYCLES**

- A. The Starcool 110V compressor is located under the vehicle.
- B. When the ambient temperature is not very high, the compressor can cycle.
- C. If the compressor cycles rapidly, it may indicate a low refrigerant level. This is not an uncommon problem with any A/C.

**5. STARCOOL COMPRESSOR DOES NOT OPERATE**

- A. Compressor failure? Highly unlikely. There has been only two in 7 years. If the compressor does not operate, it is most likely some other part is defective.
- B. Verify that vehicle's ignition is "off".
- C. Turn blower fan control switch to desired speed.
- D. Check that thermostat switch is set to "cool", and temperature selector is set below vehicle's interior temperature.
- E. Verify that 110V power is present.
- F. If 20 amp 110V circuit breaker is tripped, wait 5 minutes then reset breaker, and restart A/C system. If breaker trips again, have a qualified repair person check for a failed motor or capacitor.
- \*G. Check 12V power at thermostat. 12V power should be entering and leaving thermostat.
- \*H. Check small relay inside compressor panel, 110V power should be present on "com" terminal and on "no" terminal whenever 12V power energizes the relay coil. If not, disconnect 110V power to the van, replace relay.
- \*I. 110V power should be present at the compressor start/run (large) relay on terminal #5. If compressor still does not operate, disconnect 110V power to van and replace start/run (large) relay.

**\* IT IS RECOMMENDED THAT A QUALIFIED A/C PERSON CHECK THESE ITEMS.**

**6. STARCOOL 110V COMPRESSOR & BLOWER DOESN'T COME ON**

- A. Turn Starcool On/Off switch "On". It's located behind and above the driver's seat in the trim cornice. See photo sheet.
- B. Turn 3 speed blower fan switch to low. It's located next to the thermostat.
- C. If nothing happens turn blower switch to "Off". Leave Starcool thermostat switch on/off switch "On".
- D. Check 40 amp manual circuit breaker. "Push rest button" to reset. See photo sheet.

**1. 40 AMP MANUAL RESET CIRCUIT BREAKER**

- A. This is the "master" breaker for the Starcool system.
- B. Push button to reset.

**2. STARCOOL RELAY PLATE**

- A. Main 12V electrical control panel for Starcool A/C. Controls operation of Starcool. Also contains 12V fuses for blower fan, condensor fans and solenoid valve.
- B. See pages 12 & 13.

**3. STARCOOL RELAY PLATE "FUSES"**

- A. See page 5 – items 1, 2, 3 and 4.

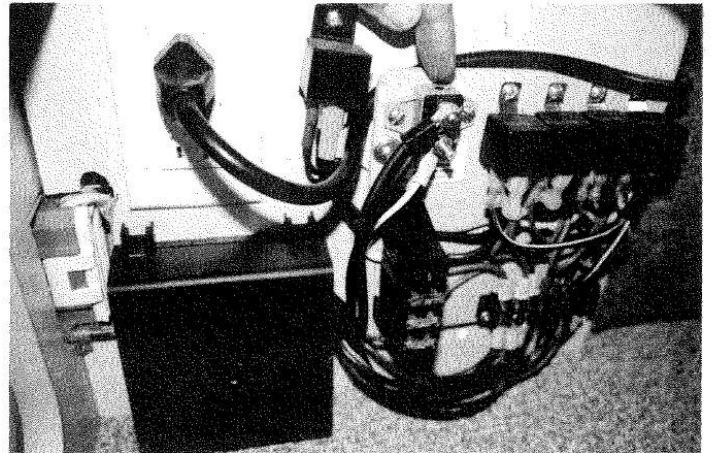
**STARCOOL AIR CONDITIONER LIMITED POLICY**

1. Starcool warrants the air conditioners sold to the original retail purchaser to be free from defects in material and workmanship under normal use for a period of 12 months or 12,000 miles, whichever comes first.
2. If a repair or adjustment is required, the Starcool may be taken to a Sportsmobile plant for repair. Please call in advance for an appointment.
3. If you are too far from a Sportsmobile plant please feel free to take your Starcool to an independent air conditioner repair company. See the yellow pages under "Automobile Air Conditioning Service". The repairing service center must contact Starcool for authorization, prior to any work being done. If warranty parts are needed, Starcool reserves the right to replace them. No warranty claims will be paid without the defective parts being returned to Sportsmobile.
4. This warranty does not cover any product which has been subject to misuse, neglect, alteration, accident, or improper maintenance, or which has been repaired without Starcool authorization in any way so as to affect adversely its performance or reliability.
5. This warranty does not cover material or labor used in normal maintenance services or the replacement of service items. This warranty does not cover loss of refrigerant unless the loss is a direct result of a defect covered by this warranty. This warranty does not cover customer lost time, vehicle towing, rental vehicles or lodging.
6. This warranty does not include consequential damages. Starcool shall not authorize any person to make for it, any warranty other than the foregoing warranty. Such other warranties, if any as may be imposed or implied by law are limited in duration to the duration of this written warranty.
7. Some states do not allow limitations on how long an implied warranty lasts, nor do they allow the exclusion or limitation of incidental or consequential damages, so the above limitation or exclusion of incidental or consequential damages may not apply.
8. This warranty gives specific legal rights, and other rights, which vary from state to state.



# **STARCOOL III SERVICE MANUAL**



**12V OPERATION**

Auxiliary condenser not shown this drawing.

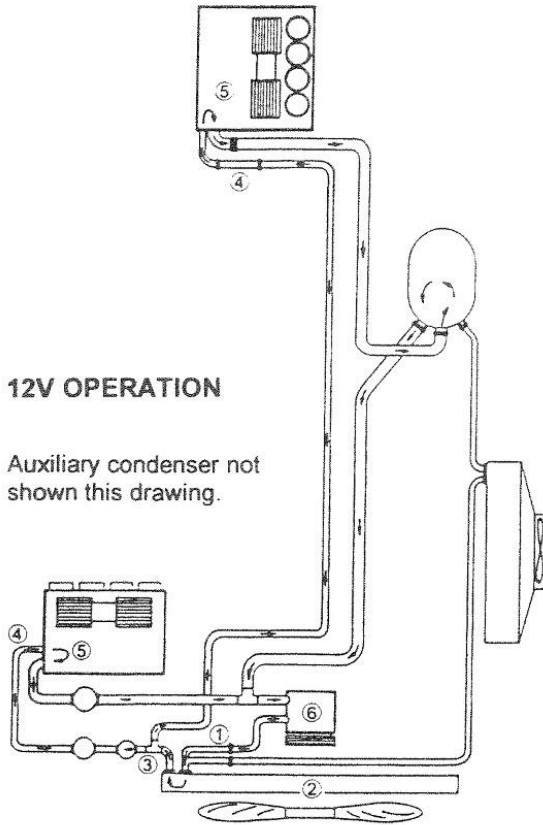

**HOW DOES THE STARCOOL WORK WHEN DRIVING? (12V)**

- ① The vehicle compressor pushes refrigerant vapor through a check-valve to the factory condenser. An additional check-valve prevents refrigerant vapor from traveling to the 110V compressor.
- ② The factory condenser lowers the temperature of the compressed refrigerant vapor and condenses it into liquid refrigerant by means of air traveling across the condenser. An auxiliary 12V condenser fan operates whenever the Starcool fan switch is on low, medium or high.
- ③ A "tee" fitting allows liquid refrigerant to flow to the Starcool orifice tube and through a normally open solenoid valve to the factory expansion valve or orifice tube. A factory receiver drier may be in the system.
- ④ The expansion valve, or orifice tube will regulate the flow of liquid refrigerant into the Starcool and factory evaporator.
- ⑤ In the evaporators, liquid refrigerant is vaporized and absorbs the interior heat when the blower fans are operating.
- ⑥ The refrigerant vapor carries the absorbed heat to the factory compressor to complete the cycle. An accumulator may be in the system before the compressor to remove moisture.

**HOW DOES THE STARCOOL WORK WHEN PARKED? (110V)**

**110V OPERATION**

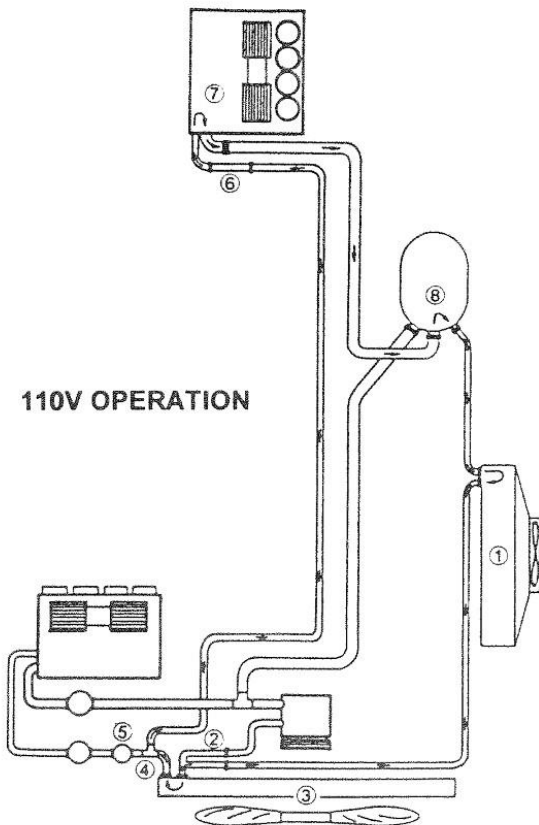

- ① The auxiliary condenser lowers the temperature of the compressed refrigerant vapor and condenses it into liquid refrigerant by means of air traveling across the condenser. The auxiliary 12V condenser fan operates whenever the Starcool 110V compressor is "on".
- ② The 110V compressor pushes refrigerant vapor through a check-valve to the factory condenser. An additional check-valve prevents refrigerant vapor traveling to the factory compressor.
- ③ The factory condenser lowers the temperature of the compressed refrigerant vapor and condenses it into liquid refrigerant by means of air traveling across the condenser. The 12V condenser fan operates whenever the Starcool fan switch is on low, medium or high.
- ④ A "tee" fitting allows liquid refrigerant to flow to the Starcool orifice tube. The normally open solenoid valve will close whenever the Starcool thermostat is set to cool and the temperature selector is set below the interior temperature of the vehicle.
- ⑤ The closing of the solenoid valve prevents liquid refrigerant from traveling to the factory evaporator.
- ⑥ The orifice tube will regulate the flow of liquid refrigerant into the Starcool evaporator.
- ⑦ In the Starcool evaporator, liquid refrigerant is vaporized and absorbs the interior heat of the vehicle when the blower fan is operating.
- ⑧ The refrigerant vapor carries the absorbed heat to the Starcool 110V compressor to complete the cycle.

## COMPONENTS / PLUMBING

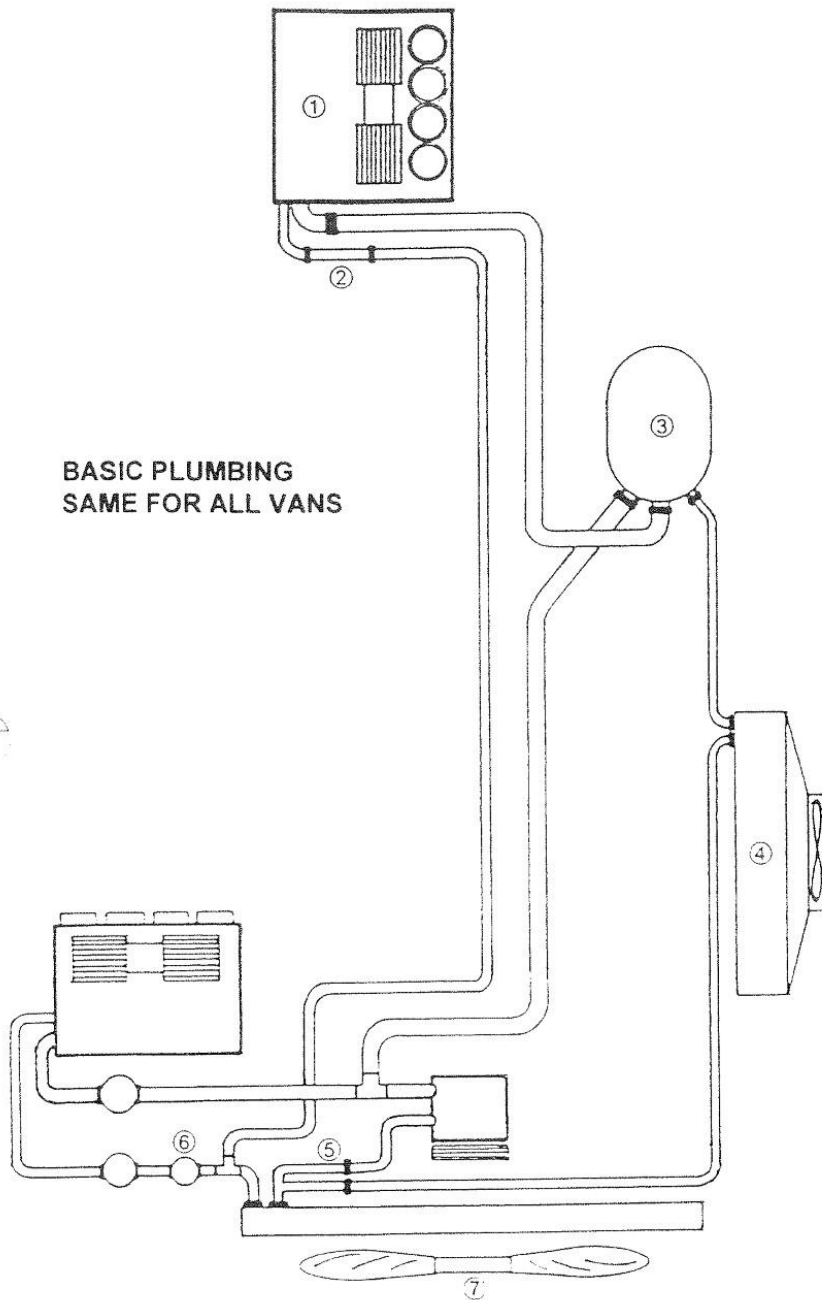
① **EVAPORATOR / BLOWER (S)**

Pulls warm interior air across coil, where refrigerant vapor absorbs heat in air and discharges cold air at vents.

② **ORIFICE TUBE (S)**

Regulates the flow of refrigerant into the evaporator coil.

③ **COMPRESSOR (S)**

Compresses refrigerant vapor from evaporator and pushes refrigerant vapor to condenser.

④ **AUXILIARY CONDENSER (S)**

Blows ambient temperature air across coils so that compressed refrigerant vapor will change to a liquid state.

⑤ **CHECK VALVE (S)**

Prevents flow of hot refrigerant vapor to the compressor which is not operating.

⑥ **SOLENOID VALVE (S)**

Controls flow of refrigerant to vehicle dash evaporator. Closes when Starcool is operated on 110V power. Open whenever vehicle A/C is operated.

⑦ **CONDENSER FAN**

Different fan for each van. Blows ambient temperature air across vehicle condenser so that compressed refrigerant vapor will change to a liquid state before entering expansion valve.

(S) This component same for all vans.

# ELECTRICAL SYSTEM

## BASIC ELECTRICAL SYSTEM SAME FOR ALL VANS

Auxiliary condenser not shown this drawing.

### EVAPORATOR / BLOWER

Pulls warm interior air across coil, where refrigerant vapor absorbs heat in air and discharges cold air at vents.

#### WILL ONLY OPERATE WHEN:

- Starcool blower switch set to low, medium or high

#### PROTECTION INCLUDES:

- 20 amp 110V fuse on relay plate.

### THERMOSTAT

Controls operation of 110V compressor

#### WILL ONLY OPERATE WHEN:

- Starcool blower switch set to low, medium or high
- Vehicle ignition is "off".

#### PROTECTION INCLUDES:

- 5 amp 12V fuse on relay plate

### BLOWER / SWITCH

Locates by thermostat.

#### WILL ONLY OPERATE WHEN:

- Set to low, medium or high.

#### PROTECTION INCLUDES:

- 20 amp 12V fuse on relay plate.

### IGNITION "ON" SOURCE

Connects to radio switch wire.

#### WILL ONLY OPERATE WHEN:

- Ignition switch is turned "on" or to accessory

#### PROTECTION INCLUDES:

- Wire should connect to fused 10 or 15 amp, 12V ignition "on" source from radio fuse.

### CONDENSER FAN

Locates behind van grill. Blows ambient temperature air across vehicle condenser so that compressed refrigerant vapor will change to a liquid state before entering orifice tube.

#### WILL ONLY OPERATE WHEN:

- Starcool blower switch set to low, medium or high.

#### PROTECTION INCLUDES:

- 20 amp 12V fuse on relay plate.

### SOLENOID VALVE

Controls flow of refrigerant to vehicle dash evaporator  
Closes when Starcool is operated on 110V power.  
Open whenever vehicle A/C is operated.

#### WILL ONLY OPERATE WHEN:

- Starcool Blower switch set to low, medium or high.
- Thermostat set to "cool" and temperature selector set below interior temperature.
- Vehicle ignition is "off".

#### PROTECTION INCLUDES:

- 5 amp 12V fuse on relay plate.

### AUXILIARY CONDENSER FAN

Locates under van. Blows ambient temperature air across auxiliary condenser so that compressed refrigerant vapor will change to a liquid state before entering vehicle condenser.

#### WILL ONLY OPERATE WHEN:

- Starcool blower switch set to low, medium or high
- Thermostat set to "cool" and temperature selector set below interior temperature.
- Vehicle ignition is "off".

#### PROTECTION INCLUDES:

- 15 amp 12V fuse on relay plate.

### RELAY PLATE

Locates under sofa/dinette. Controls operation of Starcool A/C. Also contains 12V fuses for blower fan, condenser fans and solenoid valve

#### WILL ONLY OPERATE WHEN:

- Starcool blower switch is set to low, medium or high.
- Thermostat is set to "cool" and temperature selector is set below interior temperature.
- Vehicle ignition is "off".
- Ground wire is connected to chassis ground.

#### PROTECTION INCLUDES:

- 40 amp 12V manual reset circuit breaker
- 12V fuses on relay plate.

### COMPRESSOR / COMPRESSOR RELAY

Compresses refrigerant vapor from evaporator and pushes refrigerant vapor to condenser.

#### WILL ONLY OPERATE WHEN:

- 110V power is available (110V hookup or generator)
- Starcool blower switch set to low, medium or high
- Thermostat set to "cool" and temperature selector set below interior temperature.
- Vehicle ignition is "off".

#### PROTECTION INCLUDES:

- 20 amp 110V circuit breaker on 30 amp center
- High temperature cut-out switch.
- Ignition "on" cut-out relay
- Check valve.
- 5 amp 12V fuse on relay plate.

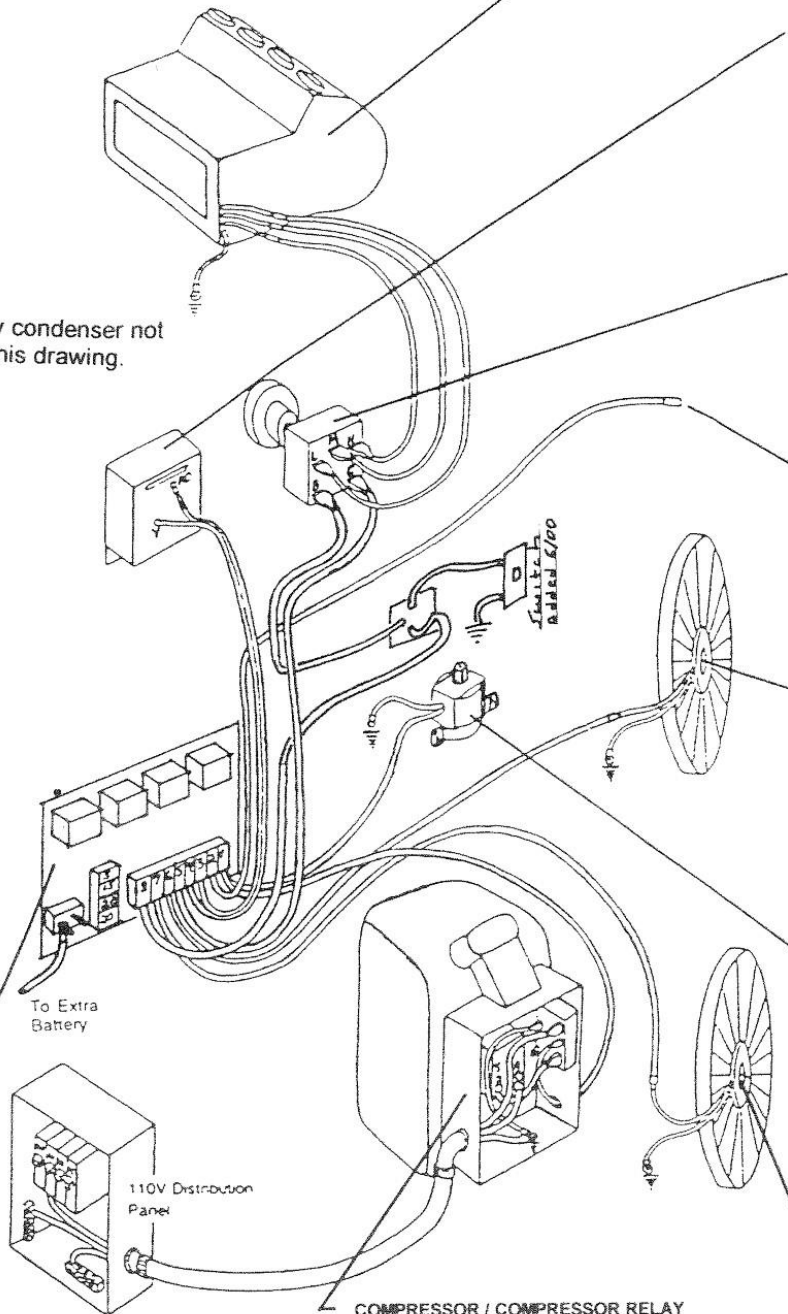

# STARCOOL III ELECTRICAL SCHEMATIC

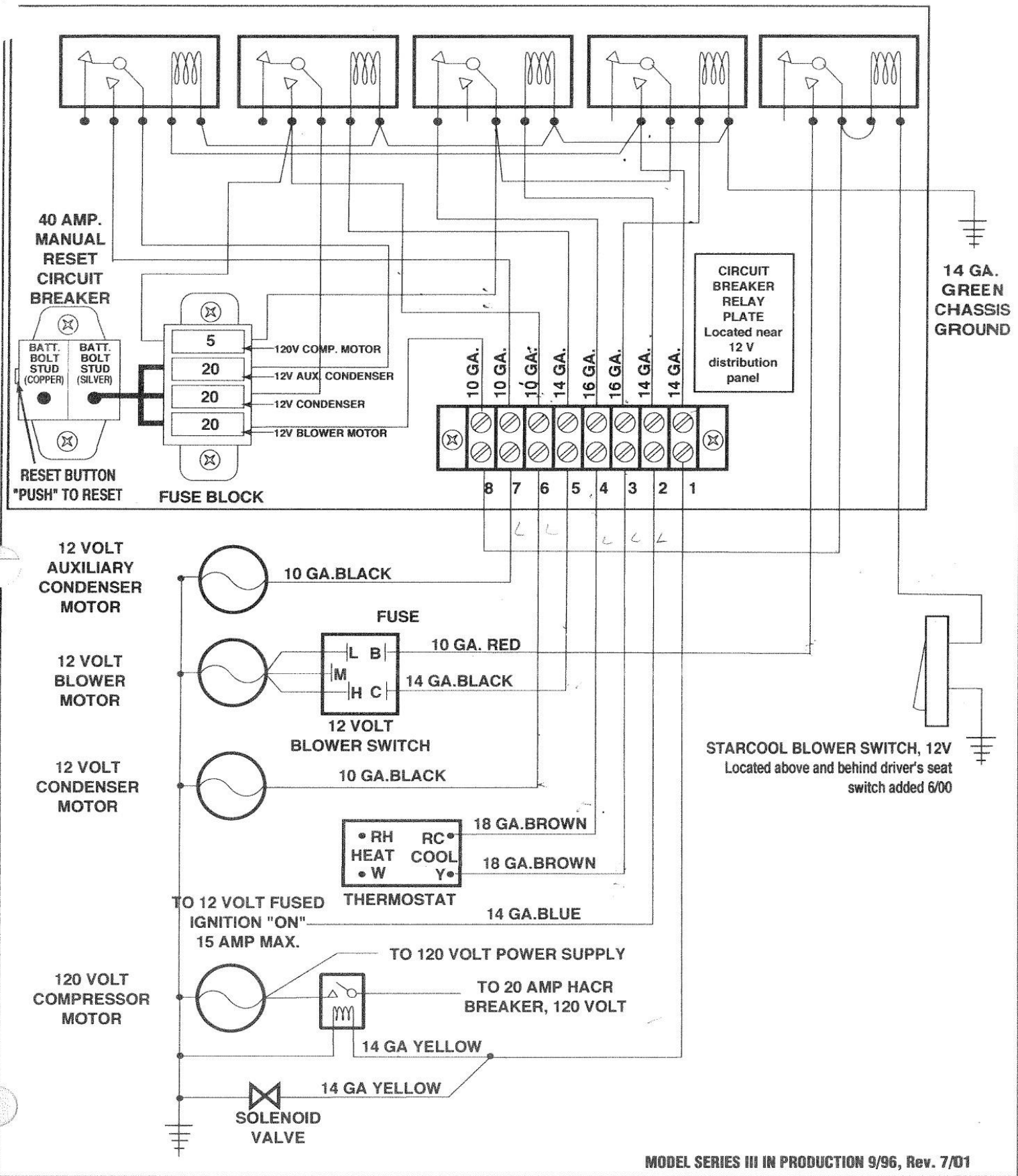



# TROUBLE SHOOTING STARCOOL NOT COOLING DURING 110 VOLT OPERATION

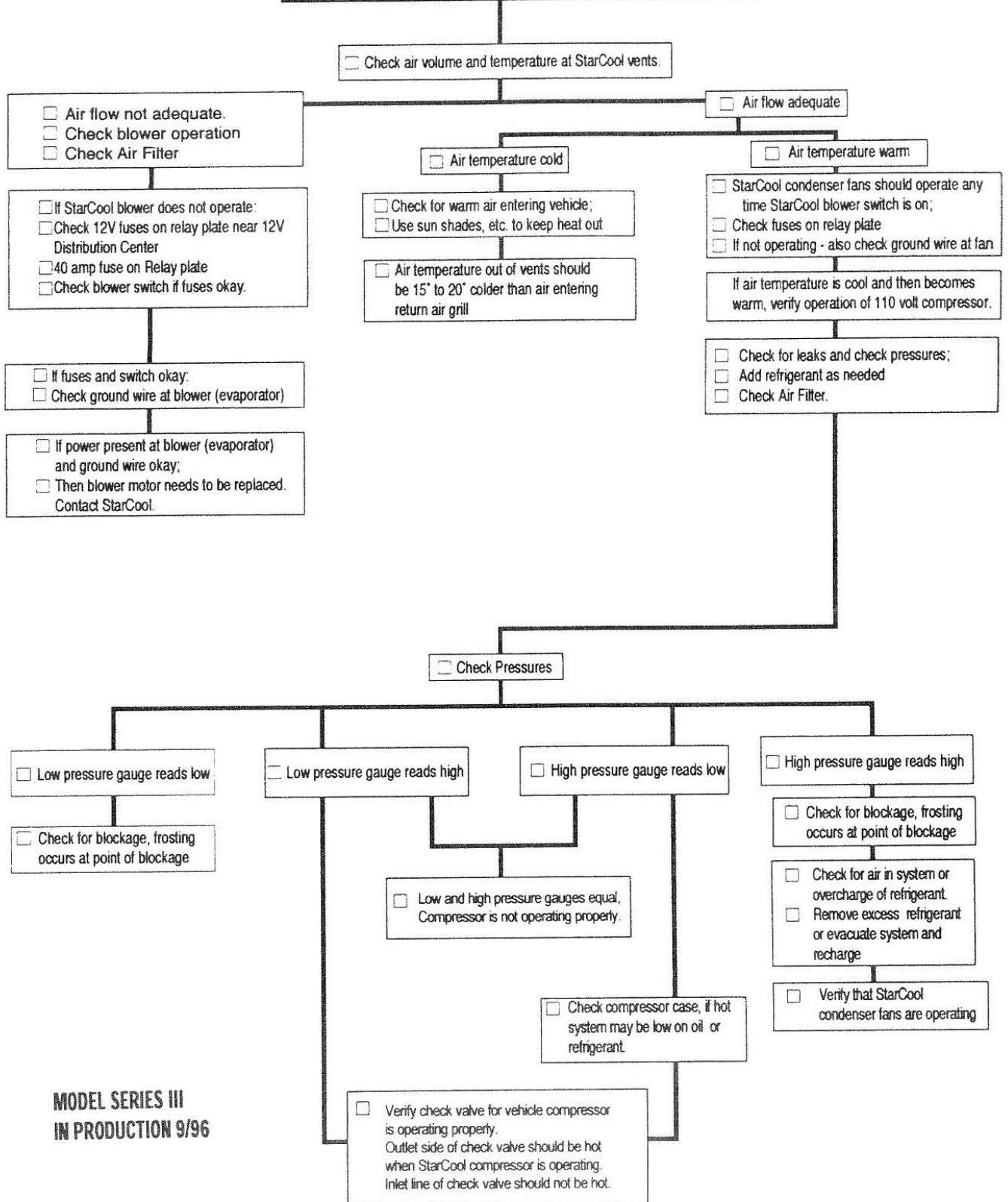

**MODEL SERIES III  
IN PRODUCTION 9/96**

# TROUBLE SHOOTING STARCOOL NOT COOLING WHILE VAN ENGINE IS RUNNING

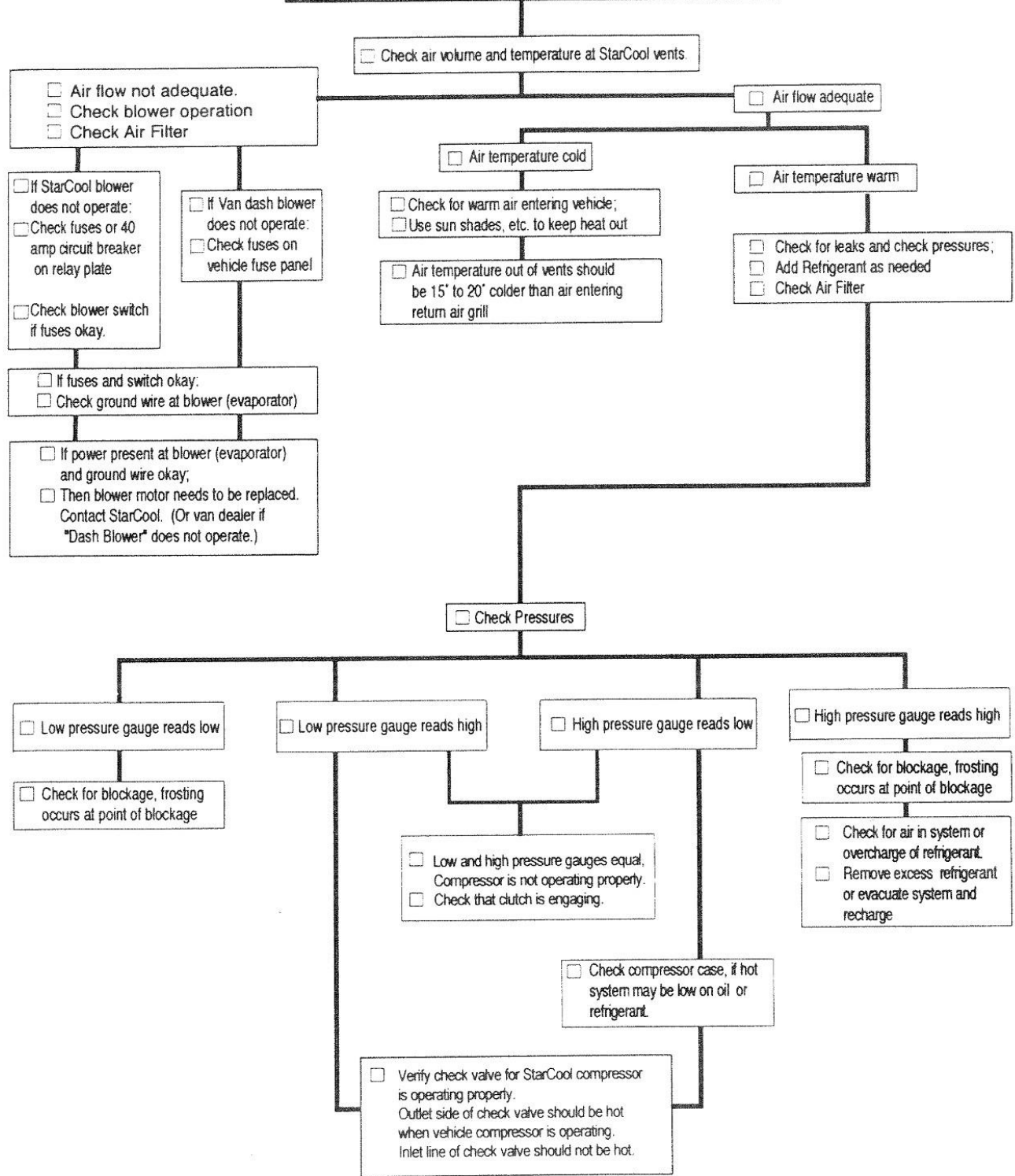

MODEL SERIES III  
IN PRODUCTION 9/96

**STARCOOL AUXILIARY AIR CONDITIONING**

- SER. NO. 0331935 ● DATE INSTLD. 1/28/04
- R-134a REFRIGERANT ● PAG OIL - 22 OUNCES ADDITIONAL
- CHARGE CAP: DODGE-4.25 LBS., FORD-4.5 LBS., GM-5LBS.

**RECLAIM REFRIGERANT ONLY - DO NOT RECYCLE**

**CAUTION** - System under high pressure. Service should be performed by qualified technicians only. Follow standard safety precautions. Wear eye protection when working with refrigerants. Refer to operator manual or call 1-800-344-8154

U.S. Patents 4,97,657 and 5,435,14